

ウィンママ 外形寸法図
WIN-MAMA
TYPE: WM-TD

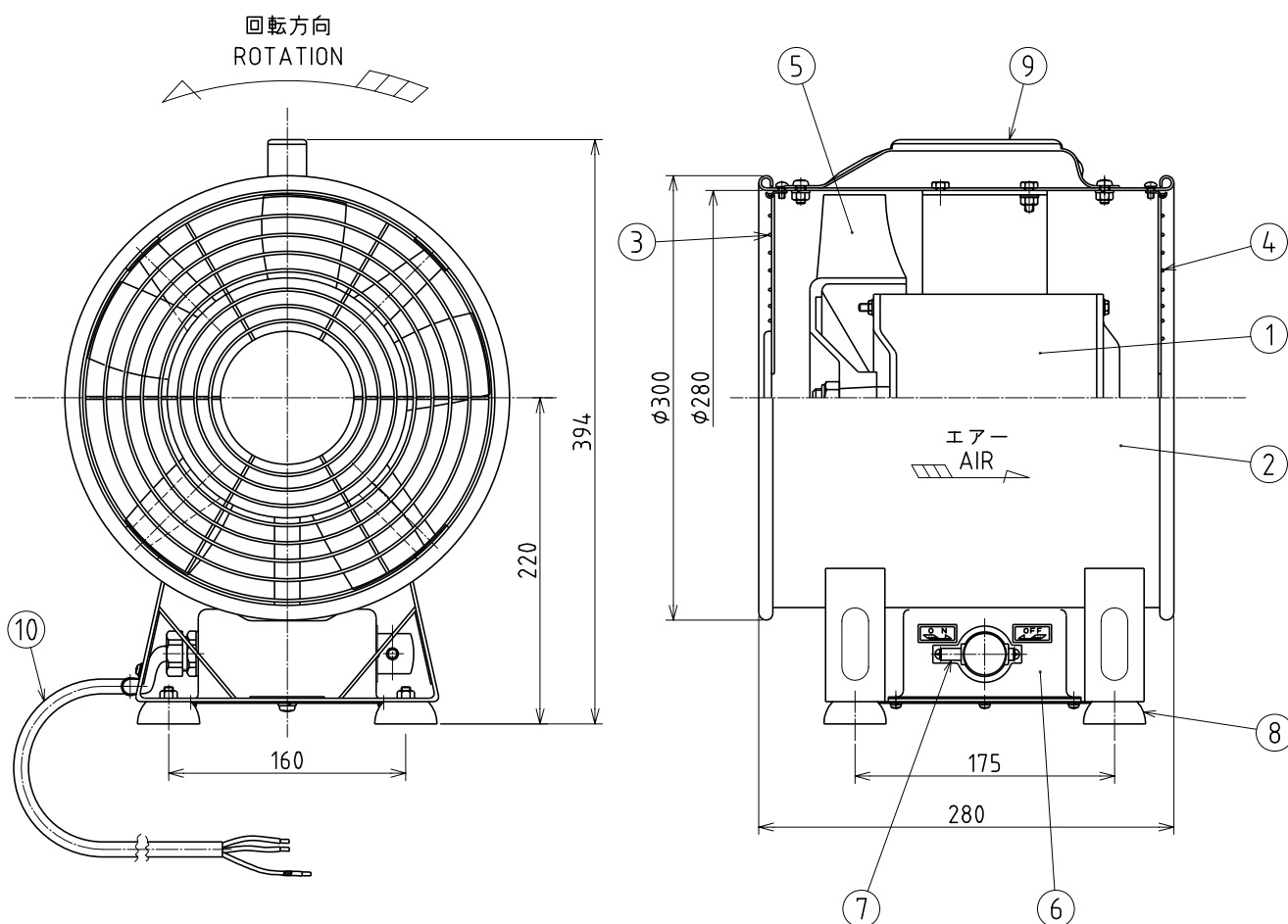

| 口径 DIS. BORE | 風量 CAPACITY | 風圧(全圧) TOTAL PRESS. | 回転数 REVOLUTION | 電圧 VOLTAGE | 周波数 FREQUENCY | 相数 PHASE | 出力 OUT PUT | 質量 MASS |
|-----------------|------------------------|------------------------|-----------------------------|---------------|------------------|-------------|---------------|------------|
| φ 280 | 70 m ³ /min | 300 Pa | 3000/3600 min ⁻¹ | AC200V | 50/60 Hz | 1 φ | 0.55 kW | 15 kg |

| | | | | | |
|-----|---------------------|---------------|-----|---------------|--|
| 10 | 電源ケーブル POWER CABLE | --- | 1 | VCT-1.25sq-3c | |
| 9 | ハンドル HUNDLE | SS400 + RESIN | 1 | | |
| 8 | 脚ゴム FOOT RUBBER | --- | 4 | | |
| 7 | スイッチ SWITCH | --- | 1 | | |
| 6 | スイッチボックス SWITCH BOX | SS400 | 1 | | |
| 5 | 羽根車 IMPELLER | PBT+GF30% | 1 | | |
| 4 | 保護金網 WIRE NETTING | SWM | 1 | 反負荷側 | |
| 3 | 保護金網 WIRE NETTING | SWM + SS | 1 | 負荷側 | |
| 2 | 風胴 CASING | SS400 | 1 | | |
| 1 | 電動機 MOTOR | --- | 1 | | |
| No. | NAME | MATERIAL | QTY | REMARKS | |

| | |
|---------------------|--------|
| 玉軸受 BALL BEARING | |
| 負荷側 | 6202ZZ |
| 反負荷側 | 6202ZZ |

| | | |
|-----------------------------------|------------|-------------|
| ONISHI ELECTRIC INDUSTRY CO.,LTD. | | |
| PROJECTION | SCALE | DATE |
| | 1:5 | JUNE.2.2008 |
| APPROVED BY | CHECKED BY | DRAWN BY |
| M.W | M.W | Y.T |

| | |
|--------------------------|---------------------|
| ポータブルファン PORTABLE FAN | |
| TYPE | WM-TD (WIN-MAMA) |
| DWG.No. | FA432034B-S |